

**HYUNDAI**  
POWER PRODUCTS

# **GASOLINE BACKPACK BLOWER**

## **HSDT30-1**

**ORIGINAL INSTRUCTIONS**



GENUINE PRODUCT OF  
HYUNDAI CORPORATION

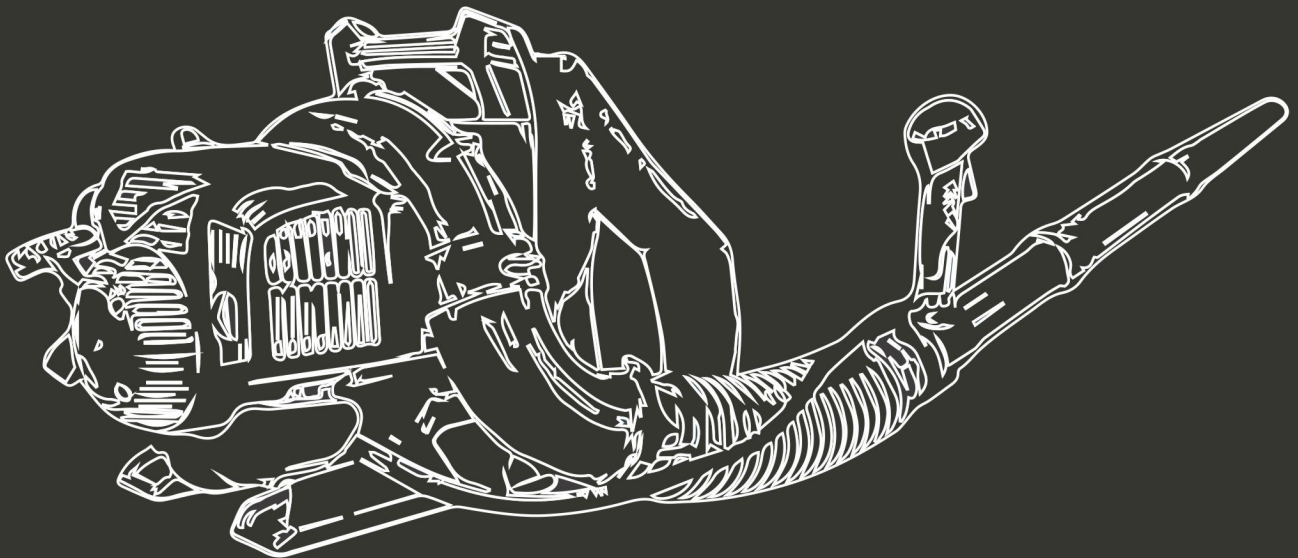

**WARNING:** Read thoroughly the instruction manual before use

## **CONTENTS**

1. SAFETY INSTRUCTIONS.....	3
2. YOUR TOOL.....	7
3. ASSEMBLY.....	9
4. FUELLING AND LUBRICATION.....	9
5. OPERATING INSTRUCTIONS.....	10
6. MAINTENANCE.....	12
7. STORAGE.....	14
8. DISPOSAL.....	14
9. DECLARATION OF CONFORMITY EU.....	15
10. WARRANTY.....	16
11. PRODUCT FAILURE.....	17
12. WARRANTY EXCLUSIONS.....	18

## 1. SAFETY INSTRUCTIONS



**WARNING:** For your own safety, please read this manual before attempting to operate your new unit. Failure to follow instructions can result in serious personal injury. Spend a few moments to familiarize yourself with your blower before each use. If you give this tool to another person, also hand over this manual.

**Use this tool as described in this manual. Any mishandling and any use contrary to instructions will not in any way engage the liability of the manufacturer.**

**Non-compliance with safety instructions and use can cause a risk of electric shock, fire and /or injury to persons.**

### **READ YOUR USER MANUAL THOROUGHLY BEFORE OPERATING YOUR UNIT.**

- This appliance is not intended for use by persons (including children) with reduced physical, sensory or mental capabilities, or lack of experience and knowledge, unless they have been given supervision or instruction concerning use of the appliance by a person responsible for their safety.
- Children should be supervised to ensure that they do not play with the appliance.
- Never allow children, persons with reduced physical, sensory or mental capabilities or lack of experience and knowledge or people unfamiliar with these instructions to use the machine, local regulations may restrict the age of the operator.
- Never use the machine when people, especially children, or pets are nearby.
- Remember that the operator or user is responsible for accidents or hazards occurring to persons or their belongings.
- Do not disassemble the tool yourself. Disassembly, repair or verification must be made exclusively by qualified personnel.
- **WEAR CLOSE FITTING, TOUGH WORK CLOTHING** that will provide protection, such as long slacks or trousers, safety work shoes, heavy duty work gloves, hard hat, a safety face shield, or safety glasses for eye protection. The tool is extremely noisy and requires the use of ear protection, such as a good grade of ear plugs or other sound barriers.
- Always carry the machine by its handle; never use any other part of the machine.
- **REFUEL IN A SAFE PLACE.** Open fuel cap slowly to release any pressure which may have formed in fuel tank. Always wipe unit of fuel or oil spills before starting. To prevent a fire hazard, move at least 10 feet (3meters) from fueling area before starting.
- **TURN UNIT OFF** before setting it down and also before installing or removing attachments.
- **KEEP ALL SCREWS AND FASTENERS TIGHT** and the unit in good operating condition. Never operate this equipment if it is improperly adjusted or not completely and securely assembled.
- **KEEP HANDLES DRY**, clean and free of fuel mixture.
- **STORE EQUIPMENT AWAY FROM POSSIBLE IGNITION SOURCES**, such as gas-powered water heaters, clothes dryers, or oil-fired furnaces, portable heaters, etc.
- **ALWAYS KEEP** the engine free of debris build-up.
- **OPERATION OF EQUIPMENT** should always be restricted to mature and properly instructed individuals.
- **ALL PERSONS WITH RESPIRATORY PROBLEMS** and persons operating blower in very dusty environments, should wear a dust particle mask at all times. Paper dust masks are available at most paint and hardware stores.

- Operate the machine only at reasonable hours - not early in the morning or late at night when people might be disturbed. Comply with times listed in local ordinances.
- Avoid using the machine in bad weather, especially when there is a risk of thunderstorms and lightning.
- In case of accident, immediately stop using the machine. Turn the machine off and check the problem. Do not use the machine while the machine is damaged.
- If the machine should start making any unusual noise or vibration, immediately shut off the power source and allow the machine to stop. Take the following steps before restarting and operating the machine:
  - a) Inspect for damage;
  - b) Replace or repair any damaged parts;
  - c) Check for and tighten any loose parts.
- If the machine becomes clogged, shut-off the power source before cleaning debris.
- Never operate the machine with defective guards or shields, or without safety devices in place.
- Keep the power source clean of debris and other accumulations to prevent damage to the power source or possible fire.
- Do not transport this machine while the power source is running.
- Stop the machine and make sure that all moving parts have come to a complete stop
  - a) Whenever you leave the machine;
  - b) Before clearing blockages or unclogging chute;
  - c) Before checking, cleaning or working on the machine.
- Do not tilt the machine while the power source is running.
- Operate the machine at the lowest possible engine speed to do the job. Like this, vibration and noise levels as well as the tool's wear can be kept to a minimum.
- Use rakes and brooms to loosen debris before blowing.
- In dusty conditions, slightly dampen surfaces.
- Use the full blower nozzle extension so the air stream can work close to the ground.
- Watch out for children, pets, open windows etc. and blow debris safely away.



**WARNING: DO NOT USE ANY OTHER FUEL** than that recommended in your manual. Always follow instructions in the Fuel and Lubrication section of this manual. Never use gasoline unless it is properly mixed with 2-cycle engine lubricant. Permanent damage to engine will result, voiding manufacturer's warranty.

- DO NOT SMOKE while refueling or operating equipment.
- DO NOT OPERATE UNIT WITHOUT A MUFFLER and properly installed muffler shield.
- DO NOT TOUCH or let your hands or body come in contact with a hot muffler or spark plug wire.
- DUE TO THE DANGER of exhaust fumes, never operate blower in a confined or poorly ventilated area.
- NEVER POINT BLOWER in the direction of people, animals, buildings, automobiles, or open windows, etc.
- DO NOT operate unit without inlet cover installed to prevent contact with impeller.
- DO NOT set a hot engine down where flammable material is present.
- DO NOT OPERATE UNIT FOR PROLONGED PERIODS. Rest periodically to prevent damage from vibration, damage to ears or damage to the appliance.
- Operate the machine in a recommended position and only on a firm, level surface.
- Do not operate the machine on a paved or gravel surface where ejected material could cause injury.



**WARNING: DO NOT ADD, REMOVE OR ALTER ANY COMPONENTS OF THIS PRODUCT.** Doing so could cause personal injury and/or damage the unit, voiding the manufacturer's warranty.

- DO NOT OPERATE UNIT WHILE TIRED, SICK OR UNDER THE INFLUENCE OF ALCOHOL OR DRUGS.
- DO NOT operate your unit near or around flammable liquids or gases whether in or out of doors. An explosion and/or fire may result.
- DO NOT WEAR loose clothing, scarfs, neck chains, unconfined long hair, and the like. Doing so could cause injury associated with objects being drawn into the rotating parts.
- DO NOT refuel a running engine or an engine that is hot.
- Before using, always visually inspect to see that fasteners are secure, the housing is undamaged and that guards and screens are in place. Replace worn or damaged components in sets to preserve balance. Replace damaged or unreadable labels.
- Before starting the machine, make certain that the tube is empty.
- Keep your face and body away from the nozzle.
- Do not allow hands or any other part of the body or clothing inside the discharge chute or near any moving part.
- Keep proper balance and footing at all times. Do not overreach. Never stand at a higher level than the base of the machine when blowing material with it.
- Always stand clear of the discharge zone when operating this machine.

### **Maintenance and storage**

When the machine is stopped for servicing, inspection, or storage, or to change an accessory, shut off the power source and make sure that all moving parts have come to a complete stop. Allow the machine to cool before making any inspections, adjustments, etc. Maintain the machine with care and keep it clean.

- Store the machine in a dry place out of the reach of children.
- Always allow the machine to cool before storing.
- Replace worn or damaged parts for safety. Use only genuine replacement parts and accessories.
- Never attempt to override the interlocked feature of the guard.









### **Residuals risks**

Even if you use this product in compliance with all safety requirements, potential risks of injury and damage remain. The following hazards may arise from the structure and design of this product. Always be vigilant when using this product, so you can recognize and manage the risks early. Rapid intervention can prevent serious injury and property damage. Turn off the tool if there are any malfunctions. Have it checked by a qualified professional and have repairs carried out, if necessary, before using it again.

- There are harmful health consequences resulting from the emission of vibrations if the product is used for long periods of time or not properly managed and properly maintained.
- There is risk of injury and property damage due to attachments or broken the sudden impact of hidden objects.
- Risk of injury to persons and property caused by flying objects.
- Prolonged use of this product exposes the operator to vibration and can produce so-called "white finger" disease. To reduce the risk, wear gloves and keep your hands warm.
- If any of the symptoms of "white finger syndrome" occur, seek immediate medical attention. Symptoms of the "white finger" include numbness, loss of sensitivity, tingling, and pain, loss of strength, color changes or skin condition. These symptoms usually appear on the fingers, hands or wrists. Risk increases at low temperatures.

- Inhalation of particles of material blown.
- Unattended projections.
- Contact with foreign objects.
- Contact with the tool in operation.
- Hearing loss in the absence of correct hearing protection.

**Symbols**

	<p>Read the user manual before using the machine.</p>
	<p>Keep bystanders away. Never work while people, especially children or pets are nearby.</p>
	<p>Keep hands out of rotation fan</p>
	<p>Always wear eye protection, ear protection and head protection.</p>
	<p>Wear foot protection.</p>
	<p>Wear gloves.</p>
	<p>Do not use the tool when the tubes are not fully assembled on it.</p>
	<p>Risk of hot surface</p>
	<p>Guaranteed sound power level according to 2000/14/EC.</p>

## Intended use

- This blower is meant to be used for blowing leaves, dust or garden debris into a desired direction. It must not be used for blowing water, chemical products, flammable material, metal or wood and other dangerous objects.
- This product is intended for private domestic use only. It must be used outdoors.
- This product is not intended to be used in a closed room and places where exhausted gas and flames can be present.
- The use of this product in case of rain or humid environments is prohibited.
- Any other use might lead to damage of the appliance, property or personal injury.

## 2. YOUR TOOL

### 2.1 Description

- |                                 |                           |                              |
|---------------------------------|---------------------------|------------------------------|
| 1. Throttletrigger              | 09. Fuel tank             | 17. Hose clamp               |
| 2. Lock-out button              | 10. Fuel cap              | 18. Muffler cover            |
| 3. On/Off ignition switch       | 11. Harness               | 19. Spark arrestor screen    |
| 4. Top assist handle            | 12. Primer bulb           | 20. Vented back pad          |
| 5. Starter handle               | 13. Control handle        | 21. Intermediate tube        |
| 6. Spark plug wire / Spark plug | 14. Operating tube        | 22. 56Mm nozzle              |
| 7. Air filter cover             | 15. Throttle linkage clip | 23. 45Mm concentrator nozzle |
| 8. Choke lever                  | 16. Flex tube             |                              |

Accessories: - Spark plug wrench with screwdriver  
- Fuel mixing canister

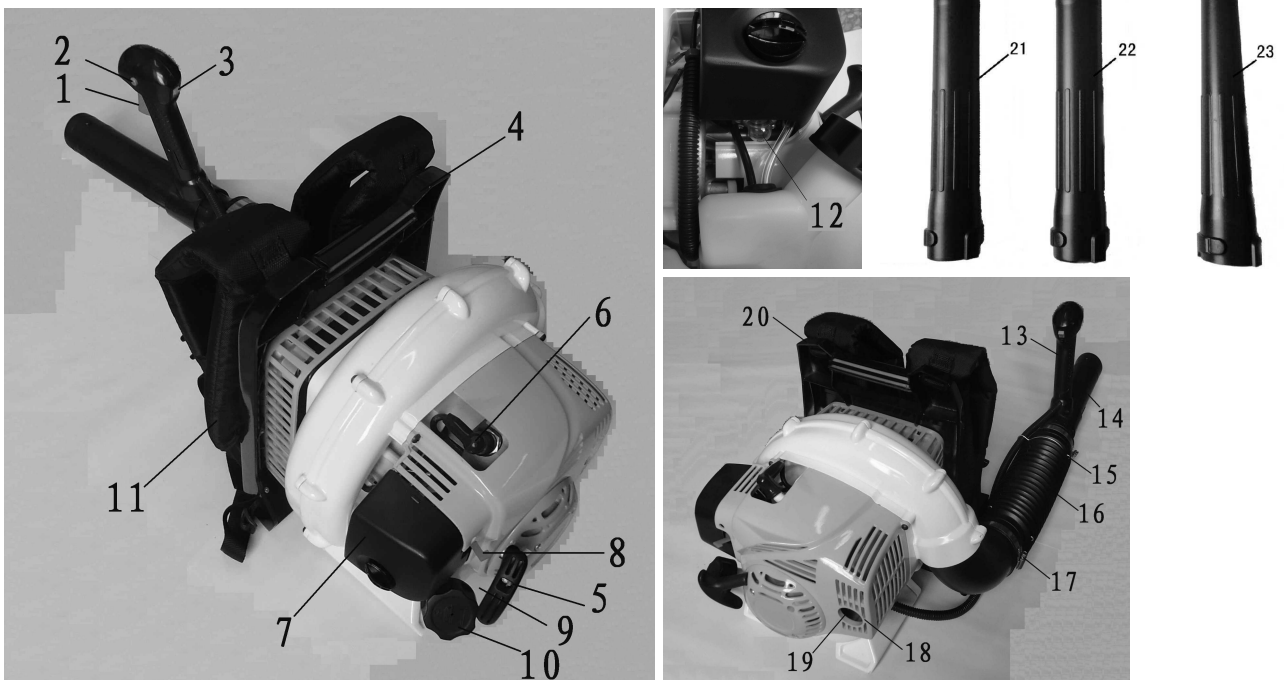

## 2.2 Technical data

<b>Model</b>	HSDT30-1
<b>Air velocity</b>	280km/h
<b>Air volume</b>	8m <sup>3</sup> /min (480 m <sup>3</sup> /h)
<b>Engine displacement</b>	26 cm <sup>3</sup>
<b>Fuel tank capacity</b>	500 ml
<b>Fuel type</b>	unleaded
<b>Fuel mixture</b>	30:1
<b>Rated engine power</b>	0.7kW /7500 min <sup>-1</sup>
<b>Idling speed</b>	3500 min <sup>-1</sup>
<b>Max engine speed</b>	9000 min <sup>-1</sup>
<b>Sound pressure level :</b>	- Idling: 82,1 dB(A) - Racing: 93,8 dB(A) - Average: 93,18 dB(A) - Uncertainly K=3 dB(A)
<b>Sound power level:</b>	- Idling: 92,31 dB(A) - Racing: 105,34 dB(A) - Average: 105,34 dB(A) - Uncertainly K=3 dB(A)
<b>Sound power level according to 2000/14/EC:</b>	- Measured: 106,4 dB(A); Uncertainty K=3 dB(A) - Guaranteed:107 dB(A)
<b>Vibration total value:</b>	- Idling: 2,241 m/s <sup>2</sup> - Racing: 1,100 m/s <sup>2</sup> - Average: 1,325 m/s <sup>2</sup> - Uncertainly K=1,5 m/s <sup>2</sup>
<b>Dry weight</b>	5.7 Kg
<b>Year of construction</b>	BJ2023



### **Wear hearing protection while operating the tool.**

The declared vibration total value has been measured in accordance with a standard test method and may be used for comparing one tool with another.

The declared vibration total value may also be used in a preliminary assessment of exposure.

### **Warning**

The vibration emission during actual use of the tool can differ from the declared total value depending on the ways in which the tool is used.

There is the need to identify safety measures to protect the operator that are based on an estimation of exposure in the actual conditions of use (taking account of all parts of the operating cycle such as the times when the tool is switched off and when it is running idle in addition to the trigger time).



### 3. ASSEMBLY

#### 3.1 Attaching flex tube

Put the hose clamp (C) on the flex tube before connecting the flex tube and the fan's outlet tube. Connect the flex tube (B) to the fan's outlet tube (A) (Fig.1) with a hose clamp (C) (Fig.2) and tighten securely (Fig.2).

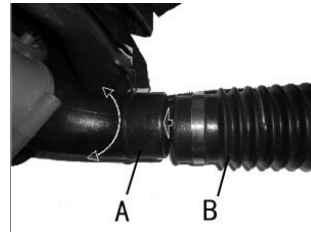

Fig.1

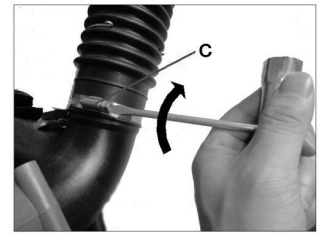

Fig.2

#### 3.2 Attaching operating tube

**NOTE:** Keep the throttle cable as straight as possible when connecting the blower tubes.

1. Place the unit on a flat surface during assembly. Ensure the screw mechanism of the clamp is positioned away from the operator.
2. Connect the hose clamp (G) on the flex tube and the operating tube with each other.
3. Turn the rotary ring mark (D) so that it aligns with the throttle handle (F). Insert the operating tube (E) into the flex tube (B) (Fig.3) and then tighten securely with a hose clamp (G) (Fig.4).
4. Attach the throttle linkage clips to both ends of the flex tube to secure the throttle cable (Fig.5 and Fig.6).

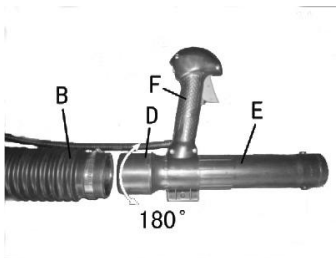

Fig.3

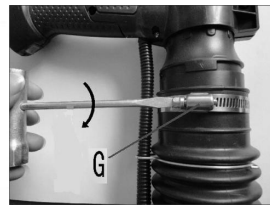

Fig.4



Fig.5

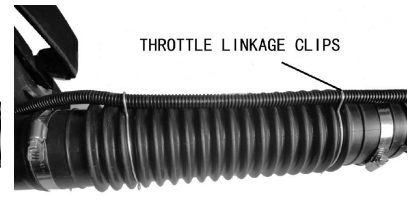

Fig.6

#### 3.3 Attaching intermediate tube and nozzles

Connect the intermediate tube (H) and one of the two nozzles (I). Push the tubes together and turn them clockwise so that they lock together (Fig.7).

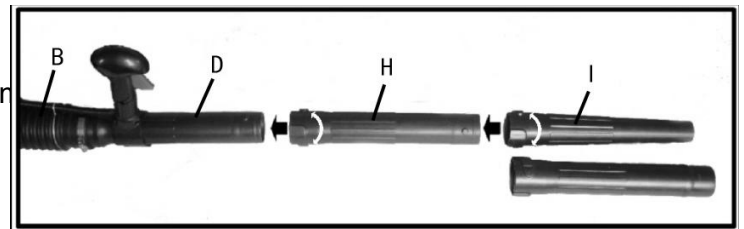

Fig.7

#### 3.4 Adjusting backpack and harness and control handle

1. Place blower on your back by slipping arms through the shoulder straps as if you were putting on a backpack.
2. Once adjustments have been made to the straps for user comfort, remove the blower from your back and place on level ground in an upright position.
3. Adjust backpack harness and control handle.

### 4 FUELLING AND LUBRICATION

#### 4.1 Fuel

Use regular grade unleaded gasoline mixed with 30:1 custom 2-cycle engine oil for best results. Use mixing ratios in the fuel mixing table below.



**WARNING:** Never use straight gasoline in your unit. This will cause permanent engine damage and void the manufacturer's warranty for the product. Never use a fuel mixture that has been stored for over 90 days.



**WARNING:** If 2-cycle lubricant other than Talon Custom Lubricant is to be used, it must be premium grade oil for 2-cycle air cooled engines mixed at a 30:1 ratio. Do not use any 2-cycle oil product with a recommended mixing ratio of 100:1. If insufficient lubrication is the cause of engine damage, it voids the manufacturer's engine warranty.

#### 4.2 Mixing fuel

Add oil to an approved fuel container followed by the gasoline to allow incoming gasoline to mix with oil. Shake container to ensure a thorough mix.



**WARNING:** Lack of lubrication voids engine warranty. Gasoline and oil must be mixed at 30:1.

##### 4.2.1 Fuel and lubrication symbols

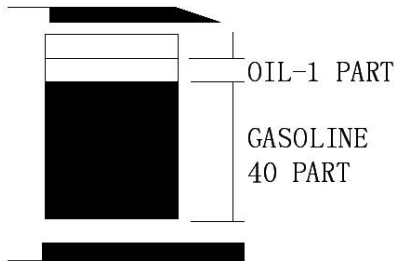

Fig.8

##### 4.2.2 Fuel and lubrication symbols

GASOLINE	30:1
Mixing Ratio	30 parts Gasoline to 1 Part Lubricant

#### 4.2.3 Recommended fuels





Some conventional gasoline are being blended with oxygenates such as alcohol or an ether compound to meet clean air standards. The engine is designed to operate satisfactorily on any gasoline for automotive use including oxygenated gasoline.

#### 4.3 Precautions for fuelling

- Always use extreme care when handling fuel! Fuel is highly flammable.
- Never attempt to fuel the blower if the fuel system components are damaged or are leaking.
- Never attempt to refuel the engine while it is running or still warm, allow it to cool before fuelling.
- Never smoke or light any fires near the blower or fuels.
- Always transport and store fuels in an approved container.
- Never place flammable material close to the engine muffler.
- Never operate the blower without a properly functioning muffler and spark arrestor installed.
- Never operate the blower unless it is properly assembled and in good working condition.
- Do not use petrol which contains ethanol or methanol as it may damage the fuel lines and other engine parts.
- Mix only enough fuel for your immediate needs. If fuel must be stored longer than 30 days, it should first be treated with a stabilizer or similar product.

### 5 OPERATING INSTRUCTIONS

#### 5.1 Starting a cold engine

1. Make sure ignition switch (A) is in the ON (I) position (Fig.9).
2. Pump primer bulb 10x by pressing on the bulb (D) (Fig.10).
3. Your unit is designed with a 2 position choke: FULL CHOKE "  "and RUN "  ". Move choke lever to position FULL CHOKE  " (Fig.11).
4. With the unit on the ground, hold the top assist handle and step on the bottom of the frame with one foot.
5. Pull the starter rope 4-6 times – if unit does not start, move choke lever to PARTIAL CHOKE by setting it between the two choke positions. Pull starter rope 4-6 more times. Wait 10 sec. after unit starts, then move choke lever to RUN "  ".

6. Push the lock-out button (C) and press throttle trigger (B) to run.

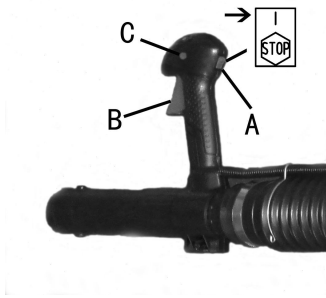

Fig.9

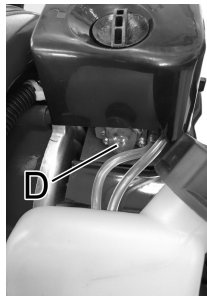

Fig.10

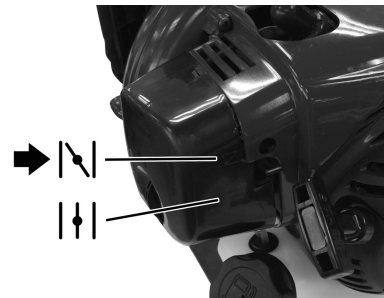

Fig.11

**NOTE:** If engine fails to start after repeated attempts, refer to Troubleshooting section.

**NOTE:** Always pull starter rope straight out. Pulling starter at an angle will cause rope to rub against the eyelet. This friction will cause the rope to fray and wear more quickly.

**NOTE:** Always hold starter handle when rope retracts. Never let a rope snap back from an extended position. This could cause the rope to snag or fray and also damage the starter assembly.

### 5.2 Important idling information

In some cases due to operating conditions (altitude, temperature etc.) your blower may need a slight adjustment to the idle speed. After warming up, if unit does not idle after restarting 2 times, follow these steps to adjust idling.

1. Locate the idle adjustment screw (G) on the carburetor (Fig.12).
2. Using a Phillips or slotted screwdriver, turn screw 1/4 to 1/2 turn clockwise (to the right). Unit should then idle properly.



Fig.12

### 5.3 Stopping the engine

#### 5.3.1 Emergency stopping procedure

When it is necessary to stop blower engine immediately, PRESS the OFF "STOP" switch (A) (Fig.13).

#### 5.3.2 Normal stopping method

For normal stopping, release trigger and allow engine to return to idle speed. Then PRESS the OFF "STOP" switch (A) (Fig.13).

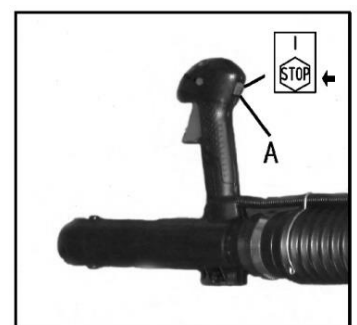

Fig.13

### 5.4 Starting a warm engine (Engine has been stopped for no more than 15-20 minutes)

1. Set throttle latch (see step 2 for starting a cold engine), pull starter rope briskly.
2. If engine does not start, or starts and then stops after 5 rope pulls, follow procedure "STARTING A COLD ENGINE".

### 5.5 Blower operations

1. Use the blower for trees, shrubs, flower beds, and hard-to-clean areas.
2. Use the unit around buildings and for other normal cleaning procedures.
3. Use the blower around walls, overhangs, fences, and screens.



**WARNING:** Because of flying debris, always use approved shielded safety glasses or a face shield when operating the blower.



**WARNING:** DO NOT operate the blower with other people or animals in the immediate vicinity. Allow a minimum of 50 feet (15 meters) between operator and other people or animals.



**WARNING:** Before using your blower, review the Safety Instructions in your user manual, and all regulations for operation of the unit. These precautions and regulations are for your protection.

4. We recommend that a face mask be worn when operating the blower in dusty areas.
5. Stand away from the debris, at a distance that will easily allow you to control the direction of blown debris. Never blow debris in direction of bystanders.
6. To control velocity of air stream, blower can be operated at any speed between idle and full throttle. Experience with the unit will help you determine the amount of airflow necessary for each application.
7. To reduce sound levels, limit the number of pieces of equipment used at any one time.
8. Check your equipment before operation, especially the muffler, air intakes and air filters.
9. Use rakes and brooms to loosen debris before blowing. In dusty conditions, slightly dampen surfaces when water is available.
11. Use intermediate tube plus nozzle of your choice so the air stream can work close to the ground.
12. After using blowers and other equipment, CLEAN UP! Dispose of debris in trash receptacles.

## 5.6 Operating instructions

1. Follow the instructions "STARTING A COLD ENGINE".
2. Once unit is running, place unit on your back by slipping arms through the shoulder straps as if you were putting on a backpack.
3. When preparing to clear an area of debris, always position yourself so that you can control the direction debris will be blown.
4. The control handle and the flexibility of the blower tube assembly will allow you to clear the most hard-to-reach areas.
5. The hand grip, throttle trigger, lock-out button and on/off ignition switch are all mounted on a swivel handle that offers a wide range of operating positions and comfort.

## 6. MAINTENANCE

**Follow these instructions to keep your machine in a good condition. A machine cleaned and in a good condition will give better operating results and preserves the life of the device. Regularly maintain your machine.**

**WARNING! Do not use products that can damage the device (abrasive, corrosive, alcohols, steam cleaners, abrasive cloths, scrapers, etc.).**

**Do not put the appliance in a dishwasher for cleaning!**

**The unit must be completely switched off and cool before cleaning.**

### 6.1 Air filter



**CAUTION:** NEVER operate blower without the air filter or dust and dirt will be sucked into the engine and damage it. The air filter must be kept clean. If it becomes damaged, install a new filter.

### To clean air filter:

1. Loosen knob (A) holding air filter cover in place, remove cover (B) and lift filter (C) from air box (Fig.14 & Fig.15).
2. Wash filter in soap and water. **DO NOT USE GASOLINE!**
3. Air-dry filter.
4. Reinstall air filter and air filter cover. Lock the knob.

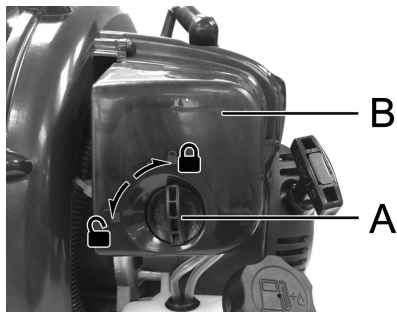

Fig.14



Fig.15

**NOTE:** Replace filter if frayed, torn, damaged or unable to be cleaned.

### 6.2 Fuel cap / Fuel filter

**CAUTION:** Remove fuel from unit and store in approved container before starting this procedure. Open fuel cap slowly to release any pressure which may have formed in fuel tank

**NOTE:** Keep vent (A) on fuel cap clean of debris (Fig.16).

#### Fuel filter

1. Completely remove fuel cap from fuel tank (B) to be able to remove fuel filter (C) from tank. Use a piece of wire (C) with a hook formed at the end to pull filter out of tank (Fig.17).
2. Pull off fuel filter (C) with a twisting motion (Fig.18).
3. Replace fuel filter (Fig.18).



**NOTE:** Never operate the blower without the fuel filter. Internal engine damage could result!

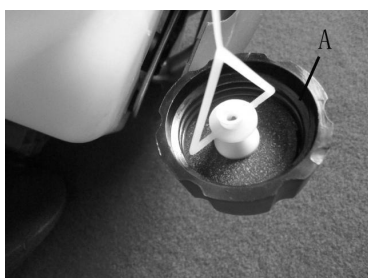

Fig.16

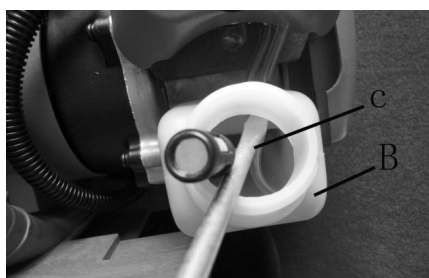

Fig.17

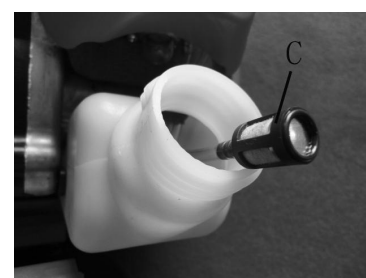

Fig.18

### 6.3 Carburetor adjustment

The carburetor was pre-set at the factory for optimum performance. If further adjustments are necessary take your blower to a qualified service dealer.

## 6.4 Spark plug

1. Check the spark plug every 10-15 hours of use.
2. To remove spark plug (Fig.19) for cleaning or replacement: Make sure engine is off, spark plug is cool, then grasp spark plug boot firmly and remove from spark plug. Remove spark plug with correct spark plug tool. Inspect, clean or replace as needed.
3. Spark plug gap = .025 in (.635mm) (Fig.19).
4. Torque to 105 to 130 inch pounds (12 to 15 Nm).
5. Reconnect spark plug boot.

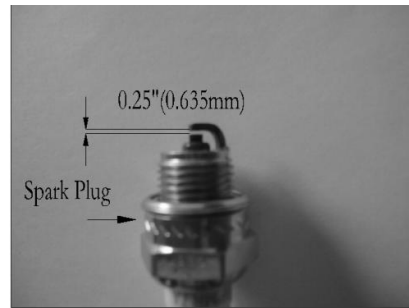

Fig.19

## 7. STORAGE



**WARNING:** Failure to follow these steps may cause varnish to form in the carburetor and difficult starting or permanent damage following storage.

1. Perform all the general maintenance recommended in the Maintenance Section of your User Manual.
2. Clean outside surface of unit.
3. Drain fuel from the fuel tank.
4. After fuel is drained, start engine.
5. Run engine at idle until unit stops. This will purge the carburetor of fuel.
6. Allow engine to cool (approx. 5 minutes).
7. Using a spark plug wrench, remove the spark plug.
8. Pour 1 teaspoon of clean 2-cycle oil into the combustion chamber. Pull starter rope slowly several times to coat internal components. Replace spark plug.
9. Store unit in a cool, dry place away from any source of ignition such as an oil burner, water heater, etc.

### Removing a unit from storage

1. Remove spark plug.
2. Pull starter rope briskly to clear excess oil from combustion chamber.
3. Clean and gap spark plug or install a new spark plug with proper gap (Fig.19).
4. Prepare unit for operation.
5. Fill fuel tank with proper fuel/oil mixture. See Fuel and Lubrication Section.

## 8. DISPOSAL

Tools, accessories and packaging should be sorted for environmentally-friendly recycling.

Do not dispose of tools in household waste!

Products those are no longer suitable for use must be separately collected and sent for recovery in an environmentally-friendly manner.

## 9. DECLARATION OF CONFORMITY

# HYUNDAI

## POWER PRODUCTS

### DECLARATION OF CONFORMITY



**BUILIDER SAS**

**ZI, 32 RUE ARISTIDE BERGES 31270 CUGNAUX, FRANCE**

**Tel : +33 (0)534.502.502 Fax : +33 (0)534.502.503**

declares that the machines:

**GASOLINE BACKPACK BLOWER**

**Model: HSDT30-1**

Serial No.:20230509356-20230509925

the people name holding the technical file: Mr.Olivier Patriarca

have been designed in compliance with the following standards:

EN 15503:2009+A2

EN ISO 14982:2009

And in accordance with the following directives:

Directive Machine 2006/42/EC

Directive EMC 2014/30/EU

Noise Directive 2000/14/EC & Annex V Directive 2005/88/EC

Emission directive 2016/1628/EU & 2018/989/EU

Sound power level:

- Idling: 92,31 dB(A)
- Racing: 105,34 dB(A)
- Average: 105,34 dB(A)
- Uncertainly K=3 dB(A)

Sound power level according to 2000/14/EC:

- Measured: 106,4 dB(A)
- Guaranteed: 107 dB(A)

Philippe MARIE / PDG

**31/03/2023**

## 10. WARRANTY

# HYUNDAI

## WARRANTY

The manufacturer guarantees the product against defects in material and workmanship for a period of 2 years from the date of the original purchase. The warranty only applies if the product is for household use. The warranty does not cover breakdowns due to normal wear and tear.

The manufacturer agrees to replace parts identified as defective by the designated distributor. The manufacturer does not accept responsibility for the replacement of the machine, in whole or in part, and/or ensuing damage.

### The warranty does not cover breakdowns due to:

- insufficient maintenance.
- abnormal assembly, adjustment or operations of the product.
- parts subject to normal wear and tear.

### The warranty does not extend to:

- shipping and packaging costs.
- using the tool for a purpose other than that for which it was designed.
- the use and maintenance of the machine done in a manner not described in the user manual.

Due to our policy of continuous product improvement, we reserve the right to alter or change specifications without notice. Consequently, the product may be different from the information contained therein, but a modification will be undertaken without notice if it is recognized as an improvement of the preceding characteristic.

### READ THE MANUAL CAREFULLY BEFORE USING THE MACHINE.

When ordering spare parts, please indicate the part number or code, you can find this in the spare parts list in this manual. Keep the purchase receipt; without it, the warranty is invalid. To help you with your product, we invite you to contact us by phone or via our website:

- **+33 (0)9.70.75.30.30**
- **<https://services.swap-europe.com/contact>**

You must create a "ticket" via the web platform.

- Register or create your account.
- Indicate the reference of the tool.
- Choose the subject of your request.
- Describe your problem.
- Attach these files: invoice or sales receipt, photo of the identification plate (serial number), photo of the part you need (for example: pins on the transformer plug which are broken).





# 11. PRODUCT FAILURE

## WHAT TO DO IF MY MACHINE BREAKS DOWN?

### If you bought your product in a store:

- a) Empty the fuel tank if your product has one.
- b) Make sure that your machine is complete with all accessories supplied, and clean! If this is not the case, the repairer will refuse the machine.

Go to the store with the complete machine and with the receipt or invoice.

### If you bought your product on a website:

- a) Empty the fuel tank if your product has one..
- b) Make sure that your machine is complete with all accessories supplied, and clean! If this is not the case, the repairer will refuse the machine.
- c) Create a SWAP-Europe service ticket on the site: <https://services.swap-europe.com> When making the request on SWAP-Europe, you must attach the invoice and the photo of the nameplate (serial number).
- d) Contact the repair station to make sure it is available before dropping off the machine.

Go to the repair station with the complete machine packed, accompanied by the purchase invoice and the station support sheet downloadable after the service request is completed on the SWAP-Europe site

For machines with engine failure from manufacturers BRIGGS & STRATTON, HONDA and RATO, please refer to the following instructions.

Repairs will be done by approved engine manufacturers of these manufacturers, see their site:

- <http://www.briggsandstratton.com/eu/fr>
- <http://www.honda-engines-eu.com/fr/service-network-page;jsessionid=5EE8456CF39CD572AA2AEEDFD290CDAE>
- <https://www.rato-europe.com/it/service-network>

**Please keep your original packaging to allow for after-sales service returns or pack your machine with a similar cardboard box of the same dimensions.**

**For any question concerning our after-sales service you can make a request on our website <https://services.swap-europe.com>**

**Our hotline remains available at +33 (9) 70 75 30 30.**



# 12. WARRANTY EXCLUSIONS

## THE WARRANTY DOES NOT COVER:

- Start-up and setting up of the product.
- Damage resulting from normal wear and tear of the product.
- Damage resulting from improper use of the product.
- Damage resulting from assembly or start-up not in accordance with the user manual.
- Breakdowns related to carburetion beyond 90 days and fouling of carburetors.
- Periodic and standard maintenance events.
- Actions of modification and dismantling that directly void the warranty.
- Products whose original authentication marking (brand, serial number) has been degraded, altered or withdrawn.
- Replacement of consumables.
- The use of non-original parts.
- Breakage of parts following impacts or projections.
- Accessories breakdowns.
- Defects and their consequences linked to any external cause.
- Loss of components and loss due to insufficient screwing.
- Cutting components and any damage related to the loosening of parts.
- Overload or overheating.
- Poor power supply quality: faulty voltage, voltage error, etc.
- Damages resulting from the deprivation of enjoyment of the product during the time necessary for repairs and more generally the costs related to the immobilization of the product.
- The costs of a second opinion established by a third party following an estimate by a SWAP-Europe repair station
- The use of a product which would show a defect or a breakage which was not the subject of an immediate report and/or repair with the services of SWAP-Europe.
- Deterioration linked to transport and storage\*.
- Launchers beyond 90 days.
- Oil, petrol, grease.
- Damages related to the use of non-compliant fuels or lubricants.

\* In accordance with transport legislation, damage related to transport must be declared to carriers within 48 hours maximum after observation by registered letter with acknowledgement of receipt.

This document is a supplement to your notice, a non-exhaustive list.

**Attention:** all orders must be checked in the presence of the delivery person. In case of refusal by the delivery person, it you must simply refuse the delivery and notify your refusal.

**Reminder:** the reserves do not exclude the notification by registered letter with acknowledgement within 72 hours.

**Information:** Thermal devices must be wintered each season (service available on the SWAP-Europe site). Batteries must be charged before being stored.

**HYUNDAI**  
POWER PRODUCTS



GENUINE PRODUCT OF  
HYUNDAI CORPORATION

**For inquiries, please contact:**

BUILDER SAS

32 rue Aristide Bergès - Z.I. du Casque - 31270 Cugnaux - France

Tél.: +33(0)5.34.502.502 Fax.: +33(0)5.34.502.503

<http://www.hyundaipower-fr.com/>

Fabriqué en République Populaire de Chine(PRC)